

**Please, read this manual  
carefully before use!**

**Owner's Manual**



## **Direct current generator**

**KS 48V-DC**

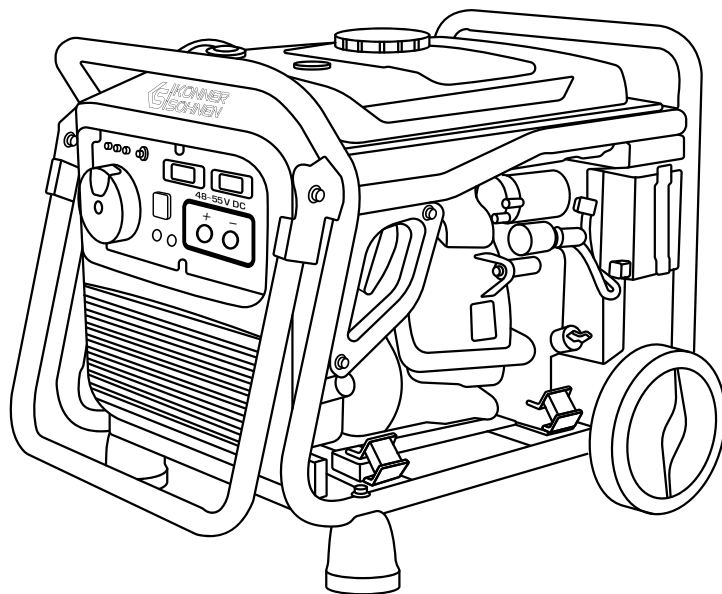



Thank you for your purchase of **Könnér & Söhnen** products. This manual contains a brief description of safety, setup and use. More information can be found on the official importer's website in the support section: [konner-sohnen.com/manuals](http://konner-sohnen.com/manuals)

You can also go to the support section and download the manual by scanning the QR code or on the website of the official importer of **Könnér & Söhnen®** at [www.konner-sohnen.com](http://www.konner-sohnen.com)



*Please, read this manual carefully before use!*

The manufacturer of **Könnér & Söhnen®** products reserves the right to make changes that may not be reflected in this manual, namely:

- The manufacturer reserves the right to make changes in the product design, configuration and construction.
- The images and drawings in this manual are for reference only and may differ from the actual components and inscriptions on the products.

Contact information that you are free to use in case of any problems can be found at the end of this manual. All information in this manual is correct to the best of our knowledge and belief at the date of its publication. The current list of service centers can be found on the official importer's website at [www.konner-sohnen.com](http://www.konner-sohnen.com)



**ATTENTION – DANGER!**



**Failure to follow the recommendations marked with this sign may lead to serious injury or death of the operator or third parties.**



**IMPORTANT!**



**Useful information while operating the machine.**

## SAFETY INFORMATION

1

Do not use the generator in rooms with poor ventilation or in conditions of excessive humidity. Do not place the generator in water or on moist soil. Do not expose the generator to rain, snow, as well as to direct sunlight for a long time. Place the generator on a flat, hard surface, away from flammable liquids/gases (at a minimum distance of 1 m). Install the generator at a distance of not less than 1 m from the front control panel and not less than 50 cm on each side, including the upper part of the generator. Keep unauthorized persons, children, and animals away from work area. Wear safety shoes and gloves.



**ATTENTION – DANGER!**



**As exhaust gases contain poisonous carbon dioxide (CO<sub>2</sub>) and carbon monoxide (CO) gases which are dangerous for life, it is strictly forbidden to install the generator in residential buildings, premises connected to residential buildings by a common ventilation system, other rooms from which exhaust gases may enter living premises.**

## ELECTRICAL SAFETY

1.1



**ATTENTION – DANGER!**



**The generator outputs a DC voltage below 60 V and requires no contact protection.**



**IMPORTANT!**



**Using device for other purposes deprives the right for free warranty.**



**ATTENTION – DANGER!**



**Be careful. Do not operate the generator, if you are tired, under the influence of drugs or alcohol. Inattention may cause a serious injury.**



**IMPORTANT!**



It is **STRICTLY FORBIDDEN TO CONNECT** to **DRY** contact (CONTROL TERMINAL) WIRES UNDER VOLTAGE. It may cause the generator to fail

## SAFETY PRECAUTIONS FOR OPERATING THE DIRECT CURRENT GENERATOR

1.2

The generator is only suitable for charging batteries (recommended for LiFePO4 batteries with a voltage of 51.2V) whose voltage range (48-55 V) matches that of the generator. The charging cables must be securely connected and have sufficient cross-section to withstand charging currents up to 70-75 A. Make sure the generator is off before refueling. **Only use unleaded automobile gasoline with an octane rating of 90 or higher!**



**ATTENTION – DANGER!**



Fuel contaminates the land and groundwater. Do not allow the leaking gasoline from the tank!

## SAFETY SYMBOLS DECRYPTION

2

### SYMBOLS DESCRIPTION WHEN WORKING WITH GENERATOR

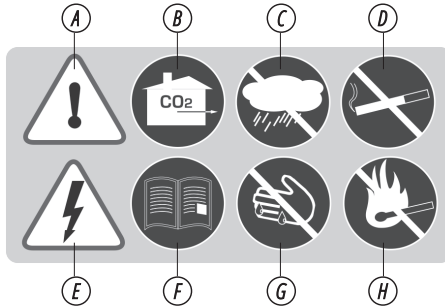

- A.** Be careful when using the device! Follow safety rules listed in manual.
- B.** Use the generator only in areas that are well ventilated, or on open areas. The exhaust gases contain CO<sub>2</sub>, which are dangerous to life.
- C.** Do not use or store the device in high humidity.
- D.** Do not smoke when using the generator!
- E.** The device generates electricity. Follow safety precautions to avoid electric shock.
- F.** Carefully read the manual before using the device.
- G.** Do not touch the generator with wet or dirty hands.
- H.** Follow fire safety rules, do not use open flames near the generator.
- I.** Please don't touch! The muffler heats up when running the generator.

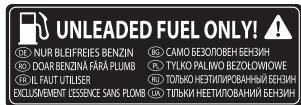

**Only use unleaded automobile gasoline with an octane rating of 90 or higher!**

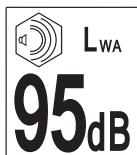

Indicates the noise level. For different models this indicator is different. All characteristics are given in the "Specifications".



Information on the required level of oil in the crankcase

**MAINTAIN AIR FILTER!**

⚠ Clean up in cleansing solvent (not flammable) and dry up once every 50 hours (every 10 hours in usually dusty conditions) and then immerse in clean engine oil until saturated, squeeze out excessive oil.

RECOMMENDED MAINTENANCE SCHEDULE



Air filter cleaning is to be performed each 50 hours of the generator operation (every 10 hours in unusually dusty conditions).

MAIN OVERVIEW

3

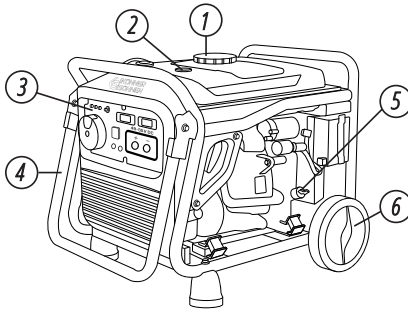

1. Fuel tank cap
2. Fuel level indicator
3. Control panel
4. Carrying handles
5. Transport wheels
6. Oil-depth gage

1. Operating indicator
2. Overload indicator
3. Low oil level indicator
4. Voltmeter
5. Amperemeter
6. The terminal for connecting the negative wire of the battery
7. The terminal for connecting the positive wire of the battery
8. Terminals for connecting the control device
9. Switch mode of the generator
10. Multifunctional engine switch

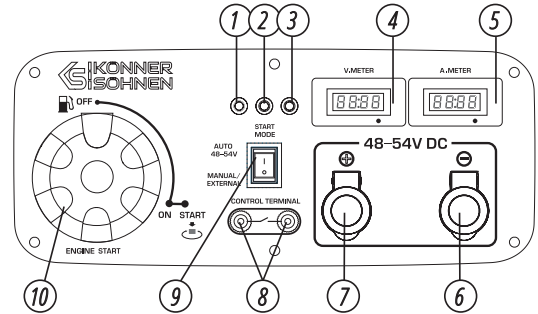

IMPORTANT!



Manufacturer reserves the right to make changes and/or improvements in design, components set and technical attributes without notice and without incurring obligation. The pictures in this manual are schematical and may not match the parameters of original product.

<b>Model</b>	<b>KS 48V-DC</b>
<b>Voltage, V</b>	48-55
<b>Nominal power, kW</b>	3.6
<b>Current, A</b>	60
<b>Start</b>	manual/auto/external
<b>Fuel tank volume, l</b>	12.5
<b>Working time at 50% load (gasoline fuel)*, h</b>	7
<b>LED display</b>	voltage, amperage
<b>Noise level Lpa (7m)/Lwa, dB</b>	70/95
<b>Engine model</b>	KS 240
<b>Engine volume, cm<sup>3</sup></b>	223
<b>Engine type</b>	gasoline, 4 stroke cycle engine
<b>Engine power, hp</b>	7.5
<b>Crankcase volume, l</b>	0.6
<b>Dimensions (LxWxH), mm</b>	650x420x425
<b>Net weight, kg</b>	36.5
<b>Protection class</b>	IP23M

\*Fuel consumption depends on many factors, such as load, fuel quality, season, altitude, technical condition of the generator.

The optimal operating conditions are ambient temperature of 17-25°C, barometric pressure of 0.1 MPa (760 mm Hg), and relative humidity of 50-60%. Under these environmental conditions, the generator can provide maximum performance in terms of the declared specifications.

In the event of deviations from these environmental indicators, the generator performance may vary.



**IMPORTANT!**



**Ensure that the control panel, protective grid, and underside of the generator are well ventilated and free from solid debris, dirt, and water. Insufficient air circulation can cause excessive heat buildup and damage the generator.**

## GENERATOR OPERATION

5

Before starting the generator, connect the battery pack to be charged. The charging cable that connects the generator to the battery pack must be secured with an 80-100 A fuse. The generator voltmeter shows the voltage of the connected battery, and the green LED (power indicator) starts flashing. The generator has no integrated battery and is activated by the battery pack to be charged. The generator can also be started with the manual starter when the connected battery is low.

A multi-function rotary selector combines a fuel valve, a generator switch and a start button.

The generator is specially designed for charging batteries and acts as a battery charger with a charging characteristic IU0. The battery is first charged with a constant current of 70-75 A until the generator output voltage reaches 53.5-54 V. After that, the generator runs with a DC output voltage. If the initial charging current is below 70 A, the output voltage will be 53.5-54 V straight away.

## POWER LED (GREEN)

The LED flashes (current consumption below 20 A) or is continuously lit (current consumption above 20 A) as long as the generator output voltage is applied to the DC output terminals.

## OVERLOAD LED (RED)

The overload LED lights up when the current consumption reaches the maximum or in case of a malfunction. The red LED is continuously lit when the battery is charging at maximum amperage.

## LOW OIL LEVEL LED (YELLOW)

When the oil level is below the lower acceptable limit, the low oil level LED lights up, and the engine stops. Insufficient oil level causes the ignition to turn off.



**IMPORTANT!**



**The overload indicator may light up within several seconds after start-up. However, this is not a malfunction.**

## BEFORE FIRST START

6

### CHECKING THE OIL LEVEL

The generator is shipped without engine oil. Always fill up the engine with engine oil before you start it.

1. Unscrew and remove the oil dipstick and wipe it with a clean, lint-free cloth.
2. Insert the dipstick without screwing it in.
3. Pull the dipstick out again and check the oil level by the marks on it.
4. If the oil level is low, refill the engine oil.
5. Finally, screw the dipstick back in.

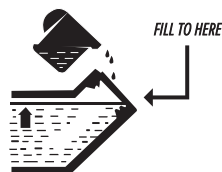

**Recommended engine oil:** SAE 10W-30, SAE 10W-40.

**Engine oil capacity:** 0.6 l.

### CHECKING THE FUEL LEVEL

The fuel tank has a fuel level gauge featuring a float, which shows only an approximate fuel level. You can only determine the exact fuel level by removing the tank cap. **Only use unleaded automobile gasoline with an octane rating of 90 or higher!**

**Fuel tank capacity:** approx. 12.5 l



**IMPORTANT!**



**Wipe up spilled fuel immediately with a clean, dry, soft cloth, as the fuel may harm painted surfaces or plastic parts.**



**IMPORTANT!**



**Use only unleaded gasoline. Using leaded gasoline can cause serious damage to the inside of the engine.**

## GETTING STARTED

7



**IMPORTANT!**



**Do not change the controller settings in terms of the amount of fuel or speed governor (this adjustment was made at the factory). Otherwise, this may result in changes in the engine operation or its failure.**



**WARNING!**



**All connecting the generator to the network must be made by certified electrician in accordance with all electrical rules and regulations.**

## COMMISSIONING

1. Fill the crankcase with engine oil. The recommended amount of oil for each model is indicated in the specification chart.
2. Check oil level with an oil dipstick. It should be between the MIN and MAX marks on the oil dipstick.
3. Check fuel level.
4. Check the air filter for correct installation
5. To connect the generator, use the original wires that come in a kit together with the generator.
6. The wires should first be attached to the terminals on the generator panel and then to the battery.
7. When connecting the wires, tighten the terminals well - both on the generator panel and on the side consumer.
8. Be sure to observe the polarity when connecting.

"+" - (red)

"-" - (black)

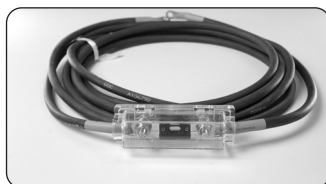

**IMPORTANT!**



**Periodically check the connections at the connection points, tighten the terminals if necessary. It is forbidden to use a cable without a fuse or if the fuse is blown**



**IMPORTANT!**



**The generator can only be used to charge the battery. It is forbidden to use the generator for direct connection to voltage consumers.**

## RUNNING THE GENERATOR IN AUTOMATIC MODE

8

In AUTO mode, the generator monitors the battery voltage and is activated automatically when the battery voltage drops to 47.5-48 V. The response time is approx. 5 seconds.

The generator charges the battery with a voltage up to 53.5-54 V and a current up to 70-75 A and shuts down as soon as the battery voltage reaches 53.5-54 V and the charging current drops below 20 A. The response time is approx. 30 seconds.

The generator can be started manually by pressing the START button at any time, regardless of the battery voltage, but it will shut down within 30 seconds after the current consumption drops below 20 A.

The green LED (power indicator) is continuously lit when the current consumption exceeds 20 A and flashes when the current consumption drops below 20 A.

Where the power consumption should never drop below 20 A (48 V busbar) for technical reasons, EXTERNAL CONTROL mode should be used so that the generator does not run continuously.



**NOTE**



**If there is no fuel in the tank the generator will do 5 attempts to start the generator, then go to error mode. To unlock, you need to update the switch to the OFF position, refuel, and follow the instructions to switch to the desired mode.**

EXTERNAL CONTROL MODE

9

The EXTERNAL CONTROL mode is enabled by closing the CONTROL TERMINAL contacts and disabled by opening them. This mode enables optimal generator integration into various power supply systems through external control of devices using “dry” contacts, thus considerably expanding its range of applications. With a jumper fitted between the CONTROL TERMINAL contacts, the generator will kick in as soon as the multi-function rotary selector is set to “ON” and will shut down as soon as it is set to “OFF”. This application is advisable where the generator needs to be turned on and off manually, regardless of the connected battery voltage.

Multiple devices are equipped with potential-free “dry” contacts (inverters, uninterruptible power supplies, BMS batteries, battery voltage monitors, time relays, etc.), enabling various generator applications.



IMPORTANT!



**MANUAL / EXTERNAL CONTROL mode is recommended for users with good experience with equipment.**



IMPORTANT!



**It is STRICTLY FORBIDDEN TO CONNECT TO DRY contact (CONTROL TERMINAL) WIRES UNDER VOLTAGE. It may cause the generator to fail.**

SHUTTING DOWN THE GENERATOR

10

TO STOP THE ENGINE, PROCEED AS FOLLOWS:

1. To stop the generator in any mode move the switch wheel to the OFF position.

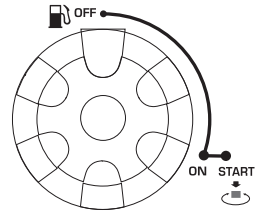

MAINTENANCE

11

This manual compliance! You can find a list of service center addresses on the website of exclusive importer: [www.konner-sohnen.com](http://www.konner-sohnen.com)

TECHNICAL MAINTENANCE WORKS

Unit	Action	At each start	First month or 20 operating hours	Every 3 months or 50 operating hours	Every 6 months or 100 operating hours	Every year or 300 operating hours
Motor oil	Level check	✓				
	Replacement		✓	✓		
Air filter	Check /Cleaning	✓	✓	✓		
	Replacement				✓	
Spark plug	Cleaning		✓	✓		
	Replacement				✓	
Fuel tank	Level check	✓				
	Cleaning					✓
Fuel filter	Check (clean out)		✓	✓		



- If the generator often operates at high temperature or high load, the oil should be replaced every 25 operating hours.
- If the engine often runs in dusty or other harsh conditions, clean the air filter every 10 operating hours.
- If you missed the maintenance time, perform it as soon as possible to save the generator engine.



**IMPORTANT!**



**The manufacturer shall not be liable for any damage caused by failure to perform maintenance work.**

## RECOMMENDED OILS

12

Use oils designed for four-stroke cycle vehicle engines SAE10W-30, SAE10W-40. Motor oils with other viscosity levels, may be used only if the average air temperature in your region does not exceed the limits of the temperature range, specified in the table.

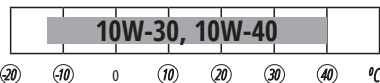

Upon oil level decrease it is necessary to add the required quantity in order to provide the correct generator operation. It is necessary to check the oil levels according to technical maintenance schedule. Further details can be found in the full version of the manual on our website.

## AIR FILTER TECHNICAL MAINTENANCE

13

Air filter cleaning is to be performed each 50 hours of the generator operation (every 10 hours in unusually dusty conditions).

### CLEANING THE FILTER:

1. Open the clips on the upper cap of the air filter.
2. Remove the sponge filtering element.
3. Remove all dirt deposits inside the hollow case of the air filter.
4. Thoroughly wash the filtering element in warmsoapy water.
5. Dry the sponge filter.
6. Dry filtering element is to be moistened by motor oil and excess oil is to be squeezed out.

## SPARK PLUGS TECHNICAL MAINTENANCE

14

Spark plug has to be intact, without soot deposits and to have a correct gap.

### SPARK PLUG VERIFICATION:

1. Remove the cap from the spark plug.
2. Remove the spark plug by means of a corresponding spanner.
3. Examine the spark plug. If it is shattered – it is necessary to replace it.  
Recommended replacement spark plugs – F7TC.
4. Measure the gap. It has to be within range 0.7-0.8 mm.
5. In case of repeated use, the spark plug has to be cleaned by means of a metal brush.  
After that – set the correct gap.

## DAMPER AND FLAME ARRESTER MAINTENANCE

15

The engine and damper will get very hot after the generator has been started. Do not touch the engine or damper with any part of your body or clothing during inspection or repair until they have cooled down.

Remove the screws and then pull the protective cover towards you. Loosen the bolts and remove the cover, screen and flame arrester of the damper. Descale the screen and flame arrester of the damper with a wire brush. Inspect the screen and flame arrester of the damper. Replace them if they are damaged. Replace the flame arrester. Replace the screen and cover of the damper. Replace the cover and tighten the screws.



**IMPORTANT!**



**Match the protrusion of the flame arrester to the hole in the pipe damper.**

**FUEL FILTER**

**16**



**IMPORTANT!**



**Never use gasoline while smoking or in the immediate vicinity of an open flame.**

1. Remove the fuel tank cap and fuel filter.
2. Clean the filter with gasoline.
3. Wipe the filter and replace it.
4. Replace the fuel tank cap.  
Make sure that the fuel tank cap is tight.

**STORAGE**

**17**

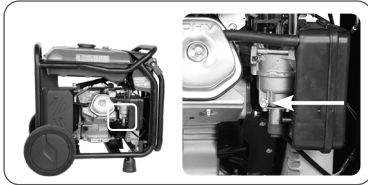

To drain gasoline from the carburetor, turn off the fuel valve and wait until the generator has cooled down sufficiently. Place a drip pan under the carburetor and loosen the drain screw on the carburetor (see fig.). Make sure that no fuel leaks onto the generator. Tighten up the screw again.

Storage room has to be dry and free from dust deposits. Storage room also has to be locked away from children and animals. It is recommended to store and use the generator at temperature of -20°C to +40°C. Avoid direct sunlight, rain on the generator. Information on long-term storage and transportation can be found in the full version of the manual.

**GENERATOR DISPOSAL**

**18**

To prevent environment damage generator should be separated from ordinary waste. Please recycle them in the safest way, passing it to special place for disposal.

**TROUBLESHOOTING**

**19**

Typical failures	Possible reason	Solution
<b>Engine will not start</b>	Rotary selector switch is in the "OFF" position	Set the rotary selector to "ON"
	No fuel in tank	Fill the tank with unleaded automobile gasoline with an octane rating of 90-95
	Fuel is old and has lost its properties	Change fuel
	Soiled carburetor	Clean the carburetor and drain the sludge
	Insufficient engine oil level	Top up engine oil to required level
<b>Decreased engine power/ troubled engine start</b>	Spark plug defective	Replace the spark plug
	Soiled carburetor	Clean the carburetor and drain the sludge
	Soiled air filter	Clean the air filter or replace it
	Spark plug defective	Replace the spark plug
<b>Engine overheated</b>	Incorrect spark plug electrode spacing	Set correct electrode spacing
	Cooling fins are dirty	Clean the cooling fins
<b>Generator shuts off and error indicator is on</b>	Air filter is dirty	Clean the air filter
	Potential battery problem (it must be charged)	Check battery parameters and remedy problems

The international manufacturer warranty is 1 year. The warranty period starts from the date of purchase. In cases when warranty period is longer than 1 year according to local legislation please contact your local dealer. The Seller which sells the product is responsible for granting the warranty. Please contact the Seller for warranty. Within the warranty period, if the product fails because of defects in the production process, it will be exchanged on the same product or repaired.

All faults caused by the manufacturer during the warranty period will be eliminated free of charge. Warranty repair is carried out only if you have a fully completed warranty card, the Buyer's signature of acceptance of the warranty terms, as well as a document supporting the purchase (cash receipt, sales slip or invoice). In the absence thereof, as well as in the event of errors or corrections not authenticated by the seller's seal or illegible inscriptions in the warranty card or tear-off coupon, no warranty repair is carried out, no objections to quality are accepted and the warranty card is withdrawn by the service center as invalid. The device is accepted for repair clean and full.



# EC Declaration of Conformity

Nr. 152

The following products have been tested by us with the listed standards and found in compliance with the European Community Machinery Directive 2006/42/EC, Electromagnetic compatibility Directive (EMC) 2014/30/EC, Noise Directive 2000/14/EC.

Manufacturer: DIMAX INTERNATIONAL GmbH  
Address: Flinger Broich 203, 40235 Duesseldorf, Germany  
Product: Direct current generator "Könner & Söhnen"  
Type / Model: KS 48V-DC

The statement is based on a single evaluation of above mentioned products. It does not imply an assessment of the whole production and does not permit the use of the test lab. logo. The manufacturer should ensure that all product in series production are in conformity with the product sample detailed in this report. The applicant should hold the whole technical report at disposal of the competent all the right.

Applied EC Directives: 2006/42/EC Machinery Directive  
2014/30/EU Electromagnetic compatibility Directive (EMC)  
2000/14/EC (+2005/88/EC) Noise Directive  
(EU) 2016/1628 Non-Road mobile machinery emissions

Applied Standards: EN ISO 3744:1995  
EN 55012:2007+A1: 2009  
ISO 8528-13:2016  
EN 60204 1:2018

Gasoline engine KS 240 corresponds to European Emission Standard STAGE V.

Notification body, responsible for 2006/42/EC Machinery Directive and 2014/30/EU Electromagnetic compatibility Directive (EMC) is ISTITUTO GIORDANO S.P.A., Via Rossini, 2; 47814 - Bellaria (RN); Country: Italy; Phone: +39 0541 343030; Fax : +39 0541 345540; Email: istitutogiordano@giordano.it; Website: www.giordano.it  
Notified Body number: 0407

Notification body , responsible for 2000/14/EC Noise Directive certificate issuing is TÜV Rheinland LGA Products GmbH, Tillystraße 2, 90431 Nürnberg, Country: Germany, Phone: +49 (0) 9116555225, Fax: +49 (0) 9116555226, Email: service@de.tuv.com, Website: www.tuv.com/safety  
Notified Body number: 0197

## 2000/14/EC\_2005/88/EC Annex VI

For model KS 48V-DC Noise measured Lwa= 93 dB (A), guaranteed Lwa= 95 dB (A)



**Issued Date:**  
**Place of issue:**  
**General director:**

2023-05-20  
Duesseldorf  
Fomin P.

*P. Fomin*

**DIMAX**  
**International**  
**GmbH**  
Steuer-Nr.: 103 5722 2493  
USt-Id-Nr.: DE296177274

We DIMAX INTERNATIONAL GmbH hereby declare that specified above conforms covering European Parliament and Council Directives, 2006/42/EC of 17 May 2006 Machinery Directive, Electromagnetic compatibility Directive (EMC) 2014/30/EC of 26 February 2014, Noise Directive 2000/14/EC of 8 May 2000. The CE mark above can be used under the responsibility of manufacturer. After completion of an EC declaration of Conformity and compliance with all relevant EC directives.

## CONTACTS

**Deutschland:**

Hergestellt unter Lizenz und Kontrolle der DIMAX International GmbH.

Importeur und Vertreter in Deutschland:  
DIMAX International GmbH Flinger Broich 203, 40235  
Düsseldorf, Deutschland. Produziert in VRC.  
innovationtrade8@gmail.com  
[www.konner-sohnen.com/de](http://www.konner-sohnen.com/de)

---

**European Union:**

Manufactured under license and control of DIMAX International GmbH, Flinger Broich 203, 40235 Duesseldorf, Germany.

Importer and representative in Netherlands DIMAX International Poland Ltd, Południowa 8 st, 05-0830 Stara Wieś, Poland. Assembled in PRC.  
innovationtrade8@gmail.com  
[www.konner-sohnen.com](http://www.konner-sohnen.com)

---

**France:**

Fabriqu e sous licence et contr ole de DIMAX International GmbH, Flinger Broich 203, 40235 D usseldorf, Allemagne.

Importateur et repr esentant en France et en Belgique DIMAX International Poland Ltd, Południowa 8 st, 05-0830 Stara Wieś, Pologne. Assembl e en RPC.  
innovationtrade8@gmail.com  
[www.konner-sohnen.com/fr](http://www.konner-sohnen.com/fr)

---

**España:**

Fabricado bajo licencia y control de DIMAX International GmbH, Flinger Broich 203, 40235 D usseldorf, Alemania.

Importador y representante en Espa a de DIMAX International Poland Ltd, Południowa 8 st, 05-0830 Stara Wieś, Polonia.  
Ensamblado en la Rep blica Popular China.  
innovationtrade8@gmail.com  
[www.konner-sohnen.com/es](http://www.konner-sohnen.com/es)

---

**Polska:**

Wyprodukowano na licencji i pod kontrol a DIMAX International GmbH, Flinger Broich 203, 40235 Duesseldorf, Niemcy.

Importer i przedstawiciel w Polsce:  
DIMAX International Poland Sp.z o. o. ul. Południowa 8, 05-0830 Stara Wieś, Polska. Zmontowany w CRL.  
innovationtrade8@gmail.com  
[www.konner-sohnen.com/pl](http://www.konner-sohnen.com/pl)

---

**Україна:**

Виготовлено за ліцензією та під контролем DIMAX International GmbH, Flinger Broich 203, 40235 Дюссельдорф, Німеччина.

Імпортер та представник в Україні:  
ТОВ "Генератор Альянс" вул. Електротехнічна 47, 02225, м. Київ, Україна. Змонтовано в КНР  
[www.konner-sohnen.com/ua](http://www.konner-sohnen.com/ua)