

**Please, read this manual
before use!**

Manual



Gasoline tillers

KS 4HP-70

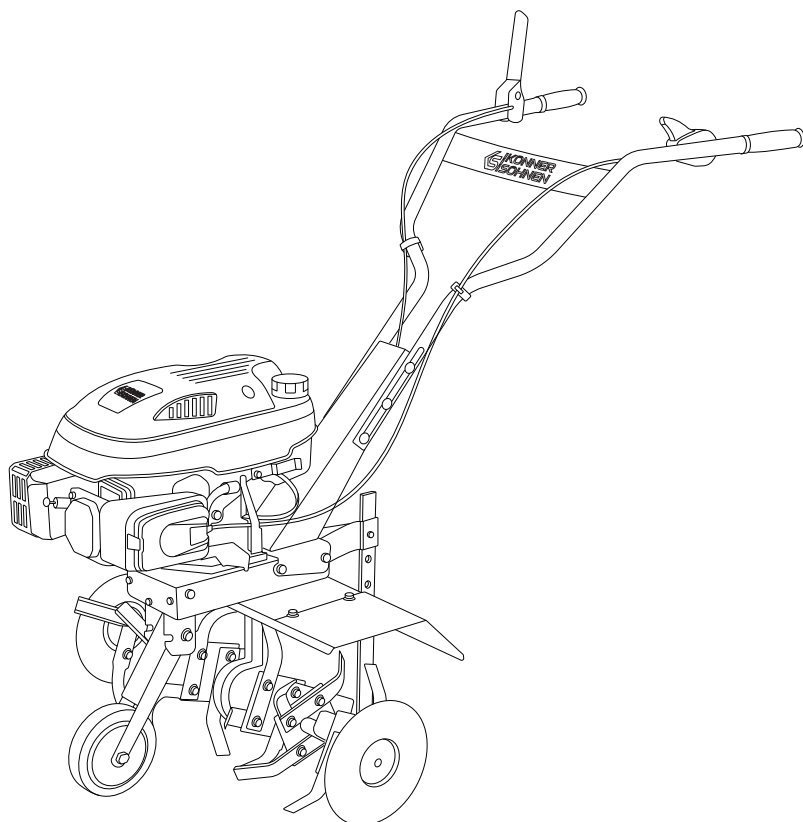



Thank you for your purchase of **Könnner & Söhnen®** products. This manual contains a brief description of safety, use and debugging. More information can be found on the official manufacturer's website in the support section: **konner-sohnen.com/manuals**

You can also go to the support section and download the full version of the manual by scanning the QR code, or on the website of the official importer of Könnner & Söhnen products: **www.konner-sohnen.com**



Please, read this manual before use!

Manufacturer reserves the right to make alterations into the product, which may not be reflected in this manual. Pictures and photos of the product may vary from its actual appearance. At the end of this manual, You may find contact information which you are free to use in case of any issues occurrence.

All data, specified in this operation manual is the most up to date for the moment of its publishing. The current list of service centers you can find at the website of official importer: **www.konner-sohnen.com**

OVERVIEW AND COMPONENTS

1

Model KS 4HP-70A – see picture 1 in the Appendix.

- | | | |
|--------|--------------------------|---------------|
| Fig. 1 | 1. Operator's panel | 6. Gearbox |
| | 2. Engine | 7. Cutters |
| | 3. Fenders | 8. Coultter |
| | 4. Plant shielding wheel | 9. Air filter |
| | 5. Transport wheel | 10. Fuel tank |



Illustrations are for reference only and may vary with the cultivator model.



SAFETY TECHNIQUE

2

Before operating the cultivator, please carefully read the owner's manual. Do not allow unauthorized people and children to operate the device. Do not use the device in close proximity to the working area of adults, children and animals - the user of the cultivator is solely responsible for personal injury and property damage. The Könnner & Söhnen power cultivator complies with the current European safety standards. Never attempt to make any changes to the design of the device.

WARNING THESE REQUIREMENTS FOR WORKING WITH THE TILLER:

1. Before getting started, please carefully read the owner's manual. Keep the owner's manual in a safe place for future reference; follow the recommendations contained therein in order to avoid personal injury and property damage.
2. Familiarize yourself with the cultivator controls and functions. In case of an emergency, the operator must know how to stop the working parts of the cultivator and its engine.
3. The operator of the device must be in good physical and mental health and be quick in decisions, if necessary. Do not operate the cultivator under the influence of alcohol, drugs or medications that can slow down the reaction.
4. The cultivator is designed to cultivate soil when sowing, as well as to handle and process plants. Do not use the cultivator for purposes other than those initially intended.

WORKING WITH THE TILLER

The device should be turned on in accordance with the instructions in the owner's manual. Make sure the operator keeps a safe distance from the working parts of the cultivator. Never place your legs or arms on the rotating parts or underneath them. To lift the device, two people must grab the handles and shafts of the cultivator. Wear special safety gloves to protect your hands and safety shoes; do not operate the cultivator in open toe shoes.

BE CAREFUL!

- The engine and exhaust pipe must be kept clean to avoid potential fire. Thoroughly check them for foliage, grass, and oil or fuel leaks.
- Watch out for the rotating parts. Do not touch the rotating cutters

**ATTENTION - DANGER!****Warning! Stop the engine before refueling, transporting and if the unit is unattended.****ATTENTION - DANGER!****The fuel contaminates the earth and groundwater. Do not allow gasoline to run out of the tank!****COMPOSITION****3**

1. Cultivator with cutters
2. Left handle
3. Clutch handle
4. Tilling depth limiter
5. Steering column
6. Transport wheel
7. Right handle (ON/OFF, speed)

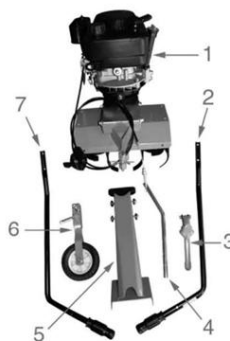
**COLLECTING THE TILLER****4****Be sure to read the full version of the manual before getting started!****ASSEMBLE THE CULTIVATOR AS ILLUSTRATED IN THE APPENDIX:**

1. Insert the coulter in the bracket - see fig. 2 in the Appendix.
2. Mount the transport wheel - see fig. 3 in the Appendix.
3. Pull the spring - see fig. 4 in the Appendix.
4. Mount the steering column - see fig. 5 in the Appendix.
5. Install the right and left handles on the control panel - see fig. 6 in the Appendix

Tiller	KS 4HP-70
Engine power, HP/kW	5,0/3,6
Engine model	KS 175
Engine capacity, cm ³	173
Tilling width, cm	≤ 70
Tilling depth, cm	≤ 27
Fuel tank volume, l	1,5
Crank case volume, l	0,6
Transmission case volume, l	0,1
Blades, psc.	24
Engine start	manual
Drive type	Belt drive, worm drive
Forward speed	+1 0
Noise level Lpa (7m)/Lwa, dB	68/93
Net weight, kg	36
Gross weight, kg	40
Net dimensions (L×W×H), mm	1350×600×800
Gross dimensions (L×W×H), mm	680×380×650



PLEASE NOTE!



Recommended oil – SAE 10W30, SAE 10W40

OPERATION INSTRUCTION

6



IMPORTANT!



The tiller is supplied without oil and fuel. Before first start-up, be sure to fill in the oil and refuel the device! Use a funnel to refuel.

COMMISSIONING

- During the commissioning:
1. Fill the crankcase with oil
 2. Fill the fuel tank with gasoline

Fill the crankcase with engine oil



Fill the fuel tank with gasoline



FUEL AND ENGINE OIL

Only unleaded gasoline is recommended for the tiller. Only use fresh, premium-grade gasoline. Use a funnel (not included) to refuel the device. Just like without fuel, the cultivator cannot work without oil, so be sure to fill the oil tank before the first start. To do this, place the device on a flat horizontal surface, open the oil tank cap and add the oil to the minimum mark. Use the oil dipstick to check the oil level. The oil filling level must be monitored at all times. Do not exceed or fall short of the oil level. Information on the used engine oil can be found in technical data of the cultivator.

Transport the cultivator to the land plot that needs to be plowed.
Start the engine.
Before cultivating the soil, raise the transport wheel.



STARTING THE ENGINE

1. Turn the engine speed control to "MAX".
2. Grasp the starter handle and slowly pull it until resistance is felt.
3. Pull the manual start cord to the full length with a sharp movement.
4. The engine will start at maximum speed.
5. Use the engine speed control to decrease the speed.
6. Press and hold down the clutch lever.
7. By pressing and holding the lever, the cultivator will begin to deepen into the ground while moving forward.

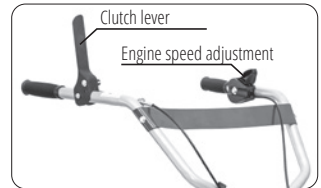

COUPLING OF WORKING PARTS

The engine clutch transmits torque from the engine to the transmission. When the clutch lever is pressed, the belts start to rotate merely to transmit the movement to the chain transmission.

NEXT STEPS

Gradually increase the plowing depth when cultivating hard soil, for which purpose apply pressure on the steering wheel to increase the coulters depth.

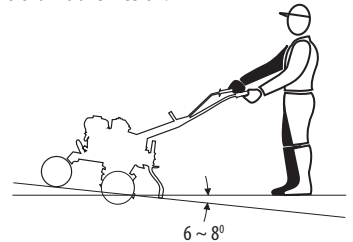

USEFUL TIPS

1. To determine the plowing depth, use the coulters at different heights. With the coulters driven deeper into the soil, the cutters also go deep into the soil and the advancement of the device forward slows down considerably.
2. The cultivator speed is determined by adjusting the engine speed. The cutters go deep into the soil with the device in the fixed position.
3. To speed up the cultivator advancement, adjust the coulters higher to lift the cutters.
4. Dry and hard ground may possibly contain big lumps and thus require two passes. Do not process raw soil, because it is difficult to break loose.
5. Immediately release the clutch lever when the cultivator is blocked by foreign objects. Kill the engine, remove obstacles and check the cultivator for deformation and damage. Replace damaged parts as necessary.

Always transport the device with the front wheel lowered. After completion of work or in between the plowing sessions, release the clutch lever and stop the engine.

STOPPING THE ENGINE

To stop the engine, reduce the engine speed by setting the engine speed lever to the “MIN” position.

MAINTENANCE

7

In order to prevent unintentional inclusion of the engine, disconnect the spark plug of the engine when storing device, transportation and all the works on cleaning and maintenance (such work is permitted only with cooled engine).

The use, storage and maintenance of **Könnér & Söhnen®** tillers must be made according to this manual. For all the damage and malfunctions, which were caused by mishandling of service, safety and working with the machine manufacturer is not responsible.

THE MANUFACTURER IS NOT LIABLE FOR:

- Using of lubricants, gasoline and motor oil, which are prohibited by supplier.
- Using the device for other purposes.
- Losses due to further use of faulty tiller parts.
- Technical changes of the device.

MAINTENANCE WORK

All works shown in “maintenance ” section should be done regularly. If you can not perform work, tiller user should contact the service center to complete an application for technical works execution. In case of losses due to injury, acquired as a result of outstanding maintenance, the manufacturer is not responsible.

MANUFACTURER IS NOT RESPONSIBLE FOR DAMAGES:

- Damage and losses resulting from the use of non-original spare parts.
- Corrosive damage and other consequences of invalid storage.
- Damage caused by the maintenance works that were carried out by unauthorized personnel.

TILLER CLEANING

Thorough cleaning and care of the device extends its life and protects it from damage. After each use, clean the tiller blades of the land, dust and grass straw. Keep under control the state of the product – damaged parts, landing threaded elements.

It is forbidden to send jets of water on the seals, engine components and bearing seats. Otherwise the tiller may need an expensive repair.



IMPORTANT!



The cultivator is delivered without oil and fuel. Before the first start, be sure to fill the device with oil and gasoline! Use a funnel (not included) to fuel the device.



ATTENTION - DANGEROUS



Oil pollutes soil and groundwater. Do not allow oil to leak out of the crankcase. Drain used oil into a sealed container. Return used oil to your local used oil collection point.

REPLACING OR ADDING ENGINE OIL

Follow the maintenance schedule and check the engine oil level on a regular basis. When the oil level drops, add fresh oil to ensure proper operation of the engine. To replace oil, proceed as follows:

1. Ensure that the cultivator is placed on a flat, level surface.
2. Place an oil drain tray under the cultivator engine.
3. Unscrew the drain cap located under the dipstick cap using a 10 mm wrench.
5. Wait for the oil to drain.
6. Replace and tighten the drain cap.

Dipstick cap

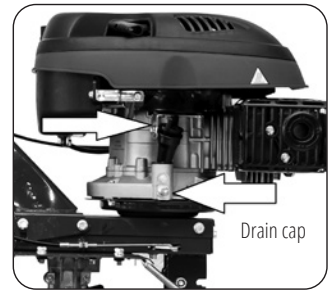

TO ADD OIL, PROCEED AS FOLLOWS:

1. Make sure the device is mounted on a flat, level surface.
2. Unscrew the dipstick cap on the engine.
3. Fill the crankcase with highly refined oil using a funnel.
4. The oil level should be as shown in Fig.

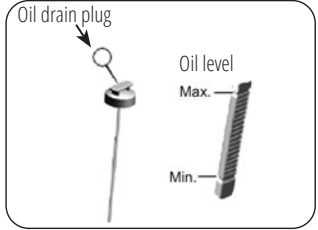

SPARK PLUG MAINTENANCE

Spark plug is an important part which provides correct and long work of the engine. It is important to keep an eye on the plug – it should not have cracks, must be installed in a right way and have no soot.

SPARK PLUG CHECKING

Recommended for use are spark plugs F6RTC, for example NGK BPR6ES. Follow this steps to check the spark plug (see the pictures below):

1. Take off the cap from the spark plug.
2. Loosen the plug with the help of candle brace.
3. Carefully check if the plug is damaged. Remove if it has any damage.
4. Measure the gap – it should be within 0,6-0,8 mm.
5. Carefully clean the spark plug with the metal brush and remove the dust before reuse of the unit. Please don't forget to measure the gap.
6. Plug in the spark plug to its place.

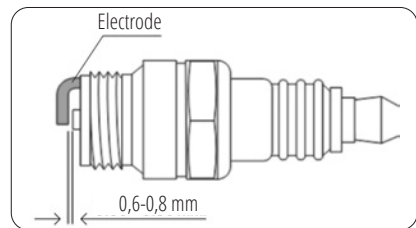
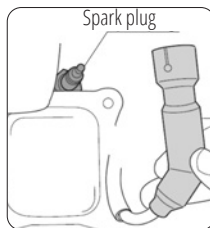

INTERNAL COMBUSTION ENGINE

To ensure the greatest service life of the engine, monitor the oil level and check oil and air filters for soiling on a regular basis. The cooling fins must be kept clean at all times to ensure sufficient cooling of the engine.

CULTIVATOR ENGINE MAINTENANCE INTERVALS

Unit	Action	Each time you start	First month or every 20 operating hours	Every month or every 20 operating hours	Every 3 month (or every 50 hours)	Every 6 month (or every 100 hours)	Every year (or every 200 hours)
Oil	Level check	✓					
	Replacement		✓		✓		
Air filter	Cleaning		✓		✓		
	Replacement					✓	
Spark plug	Cleaning		✓		✓		
	Replacement					✓	
Fuel tank	Fuel level check	✓					
	Cleaning						✓

Follow the maintenance instructions listed in the instruction manual yourself. Works that are not foreseen for self-fulfillment must be performed at an authorized **Könnner & Söhnnen** Service Center.

The addresses of the service centers can be found on our official website www.konner-sohnnen.com

AIR FILTER

To ensure proper airflow in the carburetor regular maintenance of the air filter should be conducted. From time to time it is important to check for contamination:

1. Loosen the clamp on the top cover of the air filter.
2. Remove the casing from the sponge filter element.
3. Remove dirt inside the filter casing.
4. Rinse sponge filter element in warm water, then dry it.
5. Dip a dry filter with clean engine oil and squeeze it to remove excess oil.
6. The filter cleaning should be carried out every 50 working hours of a tiller. If the engine often runs in dusty or other harsh conditions, clean the air filter every 10 operating hours.

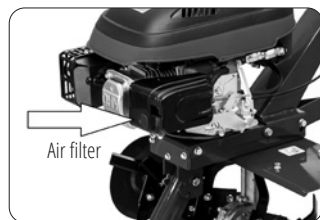

CONDITIONS OF TRANSPORTATION, STORAGE AND DISPOSAL

8



A collision with parts of the system of release or a touch of a hot engine can provoke a strong burn or flash. Allow the engine to cool completely before moving, transporting or storing the tiller.



The device is made of suitable to the secondary use materials.

The international manufacturer warranty is 1 year. The warranty period starts from the date of purchase. In cases when warranty period is longer than 1 year according to local legislation please contact your local dealer. The Seller which sells the product is responsible for granting the warranty. Please contact the Seller for warranty. Within the warranty period, if the product fails because of defects in the production process, it will be exchanged on the same product or repaired.

All faults caused by the manufacturer during the warranty period will be eliminated free of charge. Warranty repair is carried out only if you have a fully completed warranty card, the Buyer's signature of acceptance of the warranty terms, as well as a document supporting the purchase (cash receipt, sales slip or invoice). In the absence thereof, as well as in the event of errors or corrections not authenticated by the seller's seal or illegible inscriptions in the warranty card or tear-off coupon, no warranty repair is carried out, no objections to quality are accepted and the warranty card is withdrawn by the service center as invalid. The device is accepted for repair clean and full.



1. Model KS 4HP-70

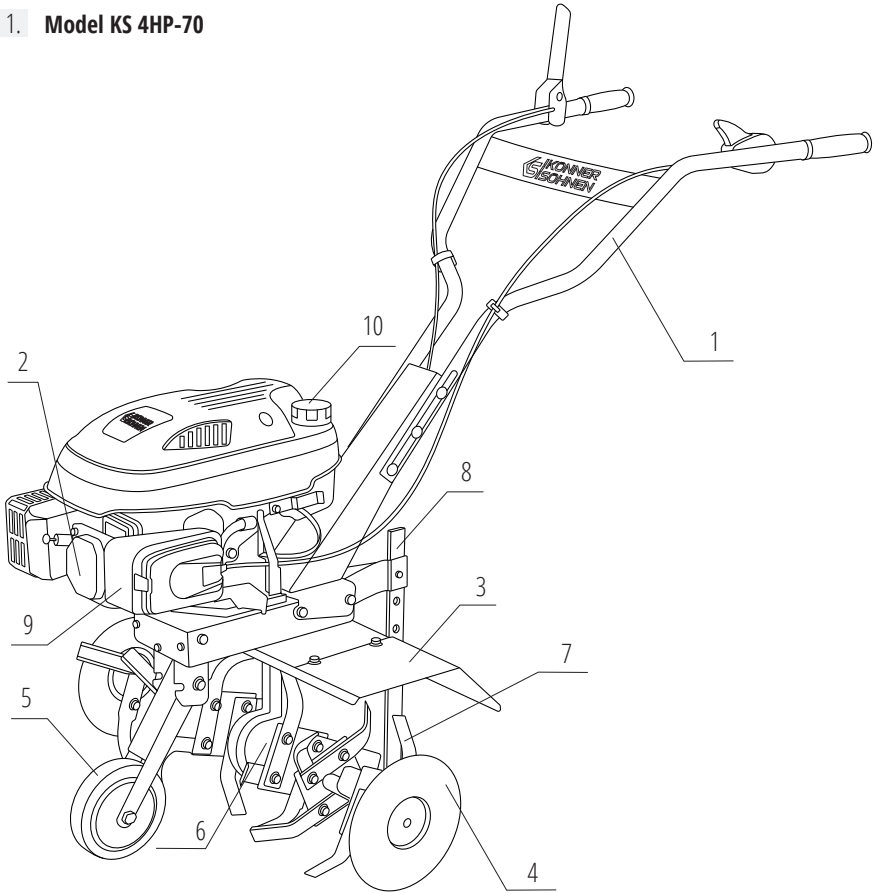

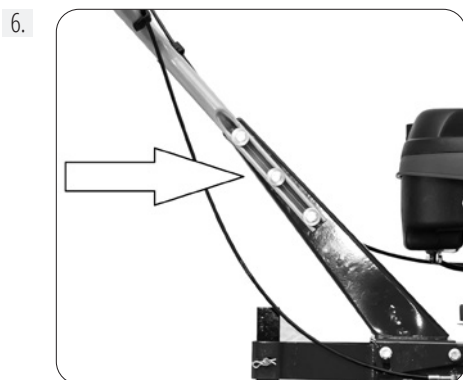
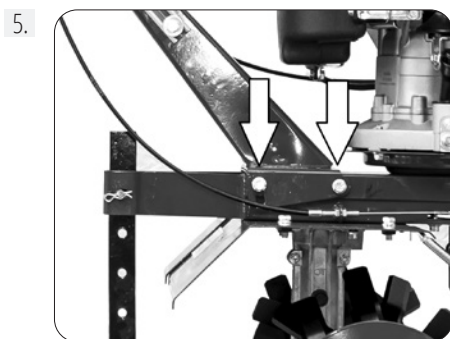
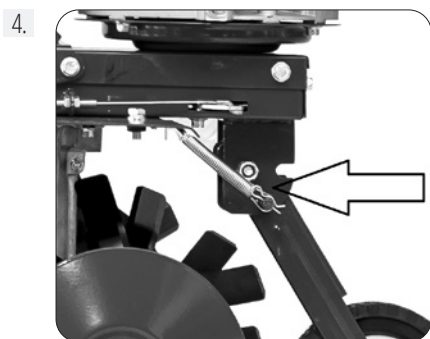
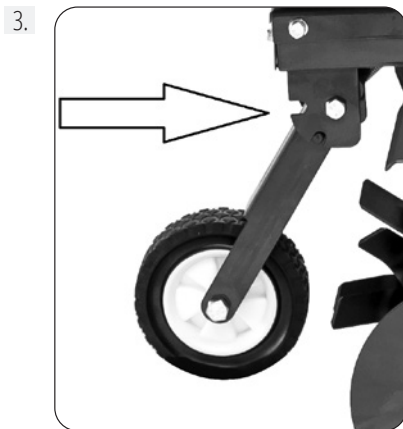
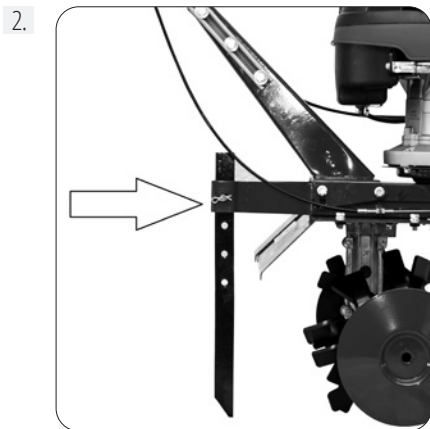



EC Declaration of Conformity

Nr. 168

The following products have been tested by us with the listed standards and found in compliance with the European Community Machinery Directive 2006/42/EC, Electromagnetic compatibility Directive (EMC) 2014/30/EC, Noise Directive 2000/14/EC.

Manufacturer: DIMAX INTERNATIONAL GmbH
Address: Flinger Broich 203 -FortunaPark- 40235 Duesseldorf, Germany
Product: Gasoline tiller "Könner & Söhnen"
Type / Model: KS 4HP-70

The statement is based on a single evaluation of above mentioned products. It does not imply an assessment of the whole production and does not permit the use of the test lab. logo. The manufacturer should ensure that all product in series production are in conformity with the product sample detailed in this report. The applicant should hold the whole technical report at disposal of the competent all the right.

Applied EC Directives: 2006/42/EC Machinery Directive
2000/14/EC Noise Directive (amended by 2005/88/EC)
2014/30/EC Electromagnetic compatibility Directive
(EU) 2016/1628 Non-Road mobile machinery emissions

Applied Standards: EN 709:1997+A4 2009
EN ISO 14982:2009
EN ISO 3744:1995, EN ISO 3744:2010 and ISO 11094: 1991

Gasoline engine KS 175 corresponds to European Emission Standard Euro V(STAGE V). This is confirmed by EU TYPE-APPROVAL CERTIFICATE granted by NSAI certification. Technical service responsible for carrying out the test -TÜV SÜD Auto servise GmbH in München, Germany
Date of issue 20/08/2019

2000/14/EC_2005/88/EC Annex VI

For model KS 4HP-70 noise guaranteed $L_{WA} = 93$ dB (A).



Issued Date: 2023-11-10
Place of issue: Duesseldorf
General director: Fomin P. *P. Fomin*

DIMAX
International GmbH
Flinger Broich 203 40235 Düsseldorf
USt-ID DE296177274
koenner-soehnen.com

We DIMAX INTERNATIONAL GmbH hereby declare that specified above conforms covering European Parliament and Council Directives, 2006/42/EC of 17 May 2006 Machinery Directive, Electromagnetic compatibility Directive (EMC) 2014/30/EC of 26 February 2014, Noise Directive 2000/14/EC of 8 May 2000. The CE mark above can be used under the responsibility of manufacturer. After completion of an EC declaration of Conformity and compliance with all relevant EC directives.

CONTACTS

Deutschland:

DIMAX International GmbH
Flinger Broich 203 -FortunaPark-
40235 Düsseldorf, Deutschland
www.koenner-soehnen.com

Ihre Bestellungen

orders@dimaxgroup.de

Kundendienst, technische Fragen und Unterstützung

support@dimaxgroup.de

Garantie, Reparatur und Service

service@dimaxgroup.de

Sonstiges

info@dimaxgroup.de

Polska:

DIMAX International
Poland Sp.z o.o.
Polska, Warczawska,
306B 05-082 Stare Babice,
info.pl@dimaxgroup.de

Україна:

ТОВ «Техно Трейд КС»,
вул. Електротехнічна 47, 02222,
м. Київ, Україна
sales@ks-power.com.ua
